

CaterSense V2 Controller

The **CaterSense V2** is one of our multi-function controllers which can be used in any catering application. The unit is able to start / stop control two fans and even speed control them via our range of external speed controllers to meet BS6173:2009 and DW172.

This product has a number of available inputs which can be used to perform different functions, such as gas pressure proving, CO2 level monitoring / control, heater battery control. Optional demand control is also available.

The stand alone CaterSense V2 is also capable of monitoring and controlling EC fans and three phase inverters.

(Please contact us for more details)



Model Type	Model	Description
	CaterSense V2	Controller - Two fans + optional sensors
Technical Data	Power supply	240Vac 50Hz (L,N,& E)
	Number of sensor channels	Two (Upgradeable with expansion modules)
	Current rating of monitor	0.4 to 10Amp - (Max FLC of fan - 9 Amps)
	Voltage range of fans	Single phase (240Vac) (Contact us for information on three phase options)
	Gas valve output	240Vac (L,N & E)
	Fire alarm input	Volt-free to open on alarm
	Remote knock-off	Volt-free to open on activation

Typical Application - Extract Fan Canopy

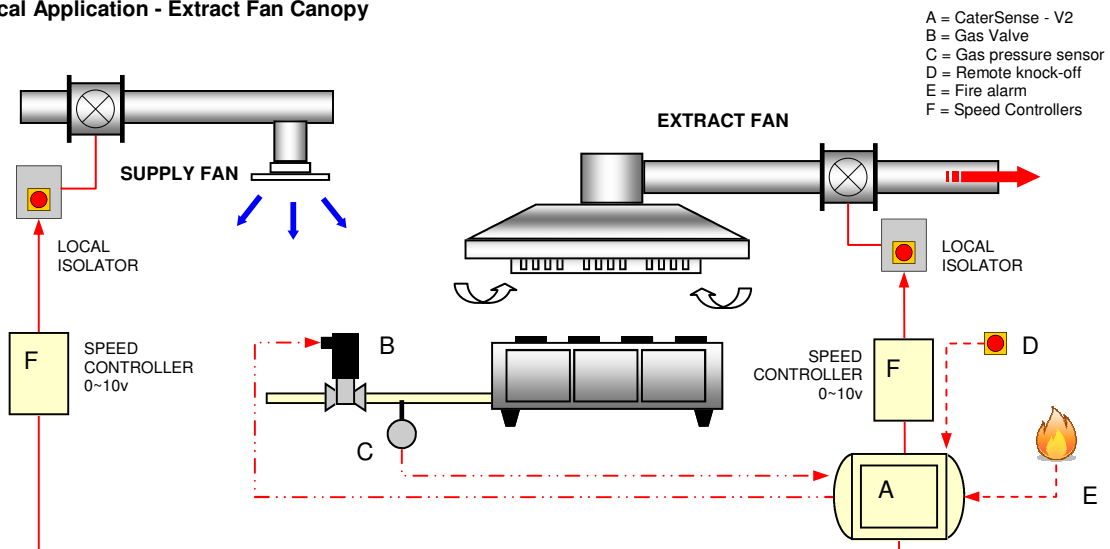

Wiring Diagram

The CaterSense system has two sets of terminals all mounted along the top edge of the main PCB circuit board.

Terminals 1 to 22 are the smaller terminals (1.5 mm² cable) and are used for the sensors, inter-locking devices, remote speed and on/off control.

Terminals 23 to 34 are the larger terminals (4 mm² cable) and are for the power connections for the fans, gas valve and power supply to the unit.

The terminals are of the rising clamp type protection.

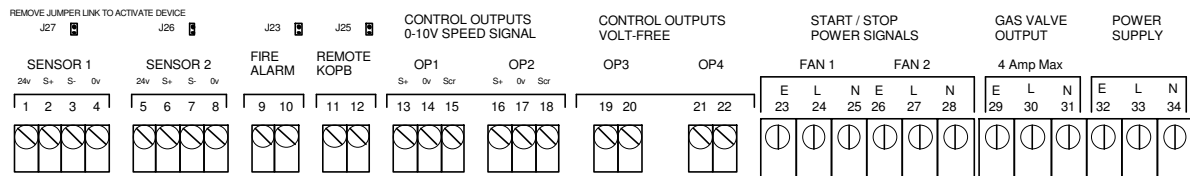

Fitting Instructions

The **CaterSense V2** unit has six (6) mounting holes which can be used (as shown)

Note: Ensure that the enclosure is mounted on a clean and level surface away from the direct cooking area or surfaces.

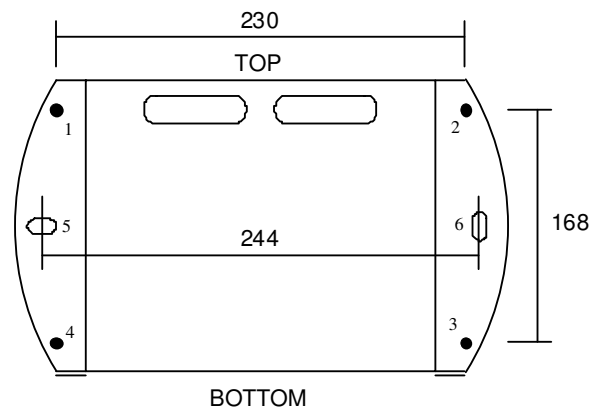

Ancillary Products

Remote Knock-off Buttons



- RKPB-01 Knock-off
- RKPB-02 Key
- RKPB-03 Key + Shroud

Remote Sensors



- CS-GPS-01
Gas Pressure
Sensor



- CS-RCT-01A
- CS-RCT-02A
- Remote Current
Sensors

Gas Valves



- GV Valves
1/2" to 2-1/2" BSP



- CS-CO2-01
Carbon Dioxide
Sensor

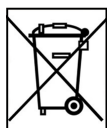

This symbol on this product or the package indicates that disposal of this product after its lifecycle could harm the environment. DO NOT dispose of this product (or batteries if used) as unsorted municipal waste. It should be disposed by a specialised company for recycling. This product should be returned to your distributor or to a local recycling service. Respect the local environment rules.