

**VariSense** the Intelligent answer



## ***VariSense models 01/02/03***

### **MULTI-FUNCTION GAS SAFETY CONTROLLER**

### **INSTALLATION and COMMISSIONING INSTRUCTIONS**

## Product Overview

The VariSense system is based on a range of products and ancillary equipment designed to meet the ever changing requirements of the gas safety industry and associated regulations.

**VariSense 01**      Intelligent controller *with Multi function solutions*

## Contents

### 1.0 General Info

- 1.01 Opening the unit
- 1.02 Fixing details
- 1.03 Cable entry
- 1.04 Electrical connections
- 1.05 System set-up (locations)

### 2.0 Set-up and commissioning

- 2.01 Initial Set-up
- 2.02 System Set-up
- 2.03 Functional Operation
- 2.04 Troubleshooting

## 1.0 General Information

### 1.01 Opening the unit

- 1) Unscrew the two cover-plate screws and the four screws securing the facia and lift the facia plate from the back box, ensuring that the ribbon cable between the two PCBs has been unplugged at the main PCB end. (Please note orientation of ribbon cable before removing)

Place the screws, and facia plate in a safe place until the back box has been fixed, wired and is ready for reassembly and set-up

### 1.02 Fixing details

The VariSense unit has four (4) mounting holes which can be used (see *Diagram 2*)

*Note: Ensure that the enclosure is mounted on a clean and level surface away from wet areas.*

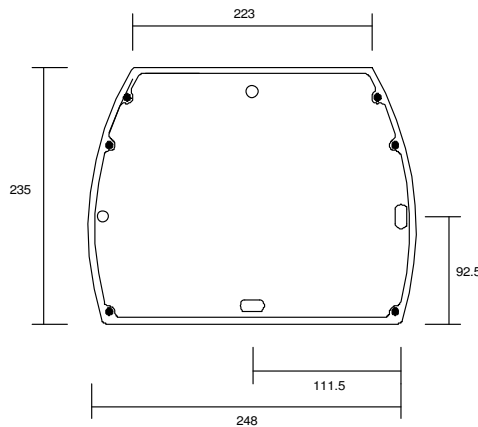

*Diagram 2: Fixing details*

### 1.03 Cable entry

The VariSense enclosure has two main areas for cable entry: the top area (223 x 40mm) and the back of the enclosure (130 x 30mm located at the top).

### 1.04 Electrical connections

The VariSense system has two sets of terminals all mounted along the top edge of the main PCB circuit board.

Terminals 1 to 22 are the smaller terminals (1.5 mm<sup>2</sup> cable) and are used for the sensors, inter-locking devices, remote speed and on/off control, screened cable must be used **(we recommend Beldon 8723 but that should be the choice of the installer and dependant on the individual installation)**.

Terminals 23 to 34 are the larger terminals (4 mm<sup>2</sup> cable) and are for the power connections for the gas valve, power supply to the unit and to a 230volt optional alarm beacon.

The terminals are of the rising clamp type protection.

All cabling should be kept to the top of the unit within the designated area. No cables should be placed or laid across the PCBs as this may cause damage.

## 1.05 System set-up

The VariSense unit has a number of intelligent control solutions. Each of which is set via a DIL (DIP) switch mounted on the main PCB circuit board.

These devices are located on the main PCB as detailed in *Diagram 3*.

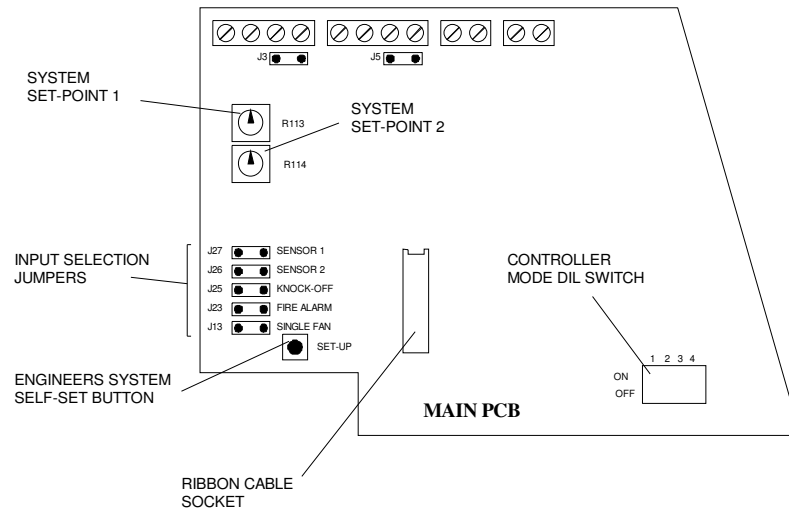

*Diagram 3: PCB locations*

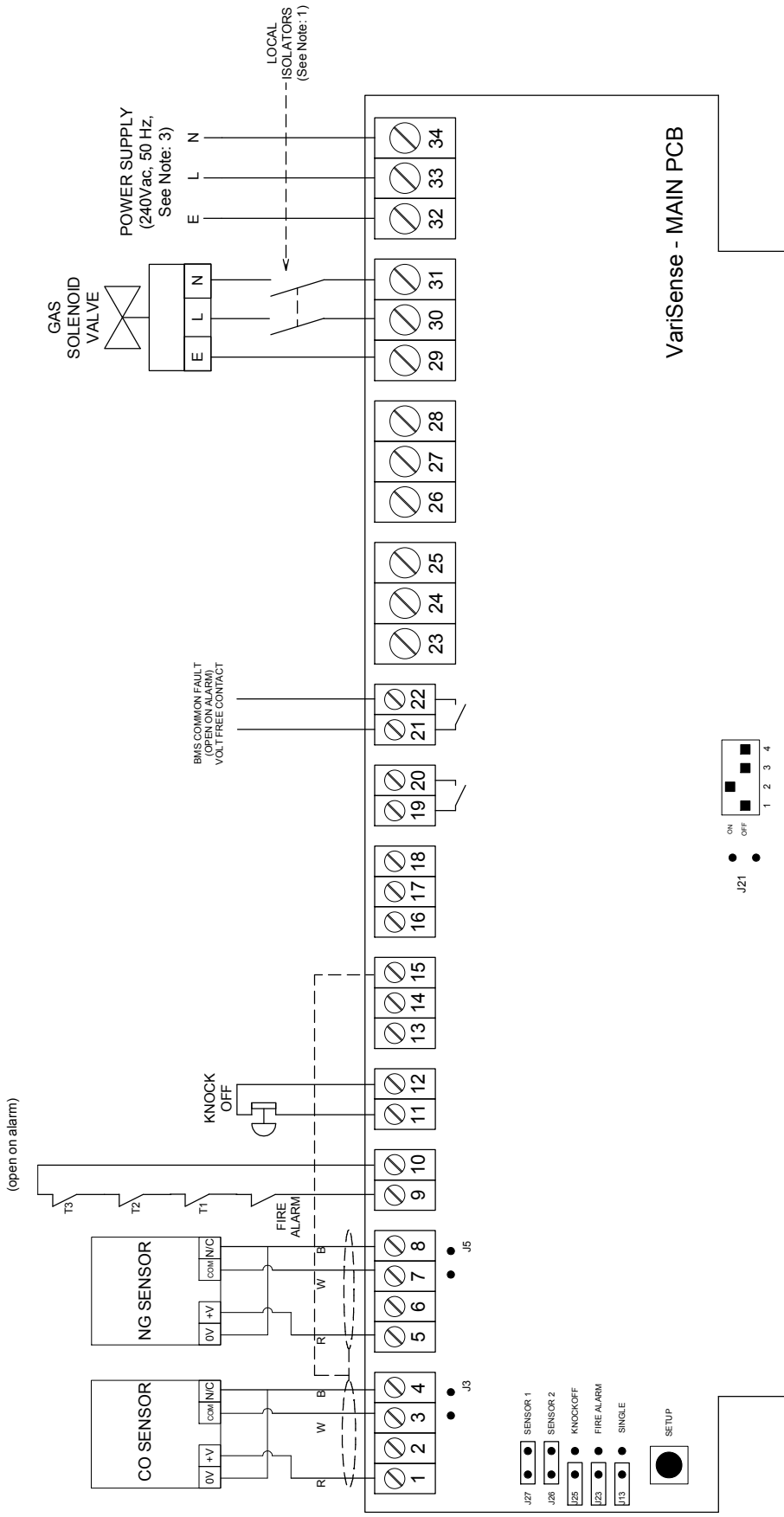

# VARISENSE-01

**TRENT**  
PRODUCTS

Tel: 01782 - 844688 Fax: 01782 - 844772

DRAWN BY

JH-P

DRAWING No:

VS-01

DATE:

07/08/2013

## 2.0 Set-up and Commissioning

The set-up and commissioning of your VariSense system is in two parts, **Initial** and **System**.

### 2.01 Initial Set-up









Once all of the wiring has been completed and tested and the system is ready to be set-up and commissioned, the following sequence **MUST** be followed to ensure the VariSense and system operate correctly.

#### a) DIL (DIP) switch set-up

Ensure the correct system code has been selected on the DIL switch.

**IMPORTANT:** Ensure power supply is switched OFF before adjusting DIL mode switch

On VariSense 01 there is a maximum of 2 sensor/detector inputs.  
To add more sensor/detectors a small expansion module (VV-EM02) extends the total to 4 and the large Expansion (VV-EM01) module to a total of 8 Sensor/detectors.

MODE	DIL (DIP) position	Number of Sensors
1		0
2		1
3		2
4		3
5		4
6		5
7		6
8		7
9		8

# VariSense the Intelligent answer

**IMPORTANT:** Ensure power supply is switched OFF before adjusting input jumpers or sensor links.

**J27** (Sensor 1) – Remove to enable Gas Pressure Proving

**J26** (Sensor 2) – Remove to allow gas pressure proving on every startup (Sensor1 must also be removed) Otherwise gas pressure proving is activated by holding the START pad for 5 seconds.

**J25** (KNOCKOFF) - If using a remote knockoff circuit in terminals 11 and 12, ensure that J25 is OFF. Otherwise, ensure J25 is ON.

**J23** (FIRE ALARM) - If using a fire alarm circuit in terminals 9 and 10 AND/OR thermal links are connected ensure that J23 is OFF. Otherwise, ensure J23 is ON.

**J13** (SINGLE) – Remove to allow automatic start on accidental power loss. When linked out the Start button will always require pressing after power loss.

## Auxiliary Connectors

**J21** ( Located near to DIL switch block) – An optional fire alarm bypass module (VS-FAB1) can be fitted to allow the fire alarm to be disabled for 5 minutes in the event of a fire alarm test.

For all other jumper connections please see wiring diagrams for further detail.

## b) Inter-lock circuits

Ensure that the fire alarm and knock-off switches (if fitted) are all in the operational position.

When all of the above stages have been completed, re-assemble the VariSense unit by reversing the sequence described above in section 1.01.

**NOTE:** Ensure the ribbon cable is plugged in correctly with the key pin (red stripe) at the **top** on the main PCB, and at the **bottom** on the facia (see Diagram 5). Otherwise this may cause damage to the PCB and the unit will not function correctly.

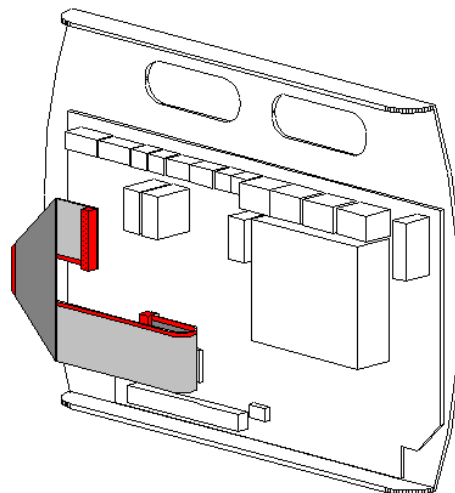

Diagram 5: Ribbon cable

## 2.02 System Set-up – VariSense

Once the above has been carried out, the system is ready to be powered up.

### Set-up sequence:

VariSense does not require commissioning however the sensor/detectors should be commissioned according to the manual provided with each item. Please contact Trent if you are unsure of how to replicate these simulations.

## 2.03 Functional operation

The operation of the CaterSense unit and system is as follows:

For modes WITH or WITHOUT gas pressure proving:

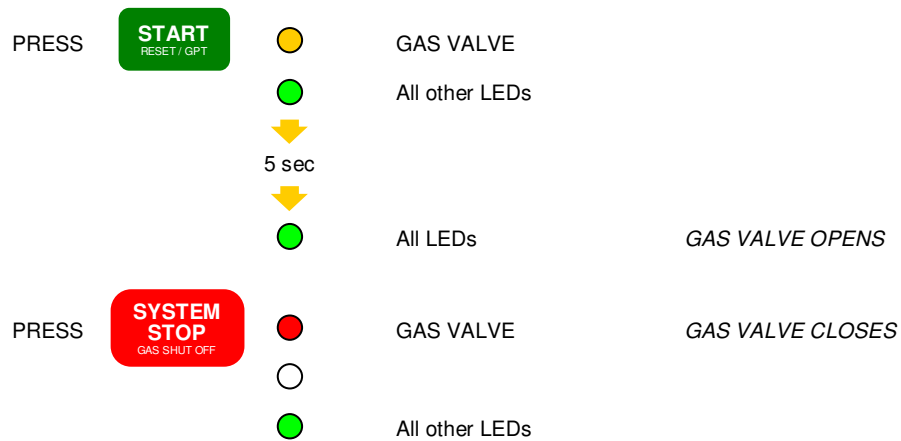



## 2.04 Troubleshooting

### 2.04.1 - SYSTEM STOPPED

- |                                                   |                                    |
|---------------------------------------------------|------------------------------------|
| <input checked="" type="radio"/> POWER ON         | <input type="radio"/> DETECTOR 1/5 |
| <input checked="" type="radio"/> GAS VALVE        | <input type="radio"/> DETECTOR 2/6 |
| <input checked="" type="radio"/> REMOTE KNOCK OFF | <input type="radio"/> DETECTOR 3/7 |
| <input checked="" type="radio"/> FIRE ALARM       | <input type="radio"/> DETECTOR 4/8 |
| <input checked="" type="radio"/> GAS PRESSURE     |                                    |

Cause: - The system has been stopped  
Solution: - Press "Start" key to begin startup sequence

### 2.04.2 - FIRE ALARM

- |                                                   |                                    |
|---------------------------------------------------|------------------------------------|
| <input checked="" type="radio"/> POWER ON         | <input type="radio"/> DETECTOR 1/5 |
| <input checked="" type="radio"/> GAS VALVE        | <input type="radio"/> DETECTOR 2/6 |
| <input checked="" type="radio"/> REMOTE KNOCK OFF | <input type="radio"/> DETECTOR 3/7 |
| <input checked="" type="radio"/> FIRE ALARM       | <input type="radio"/> DETECTOR 4/8 |
| <input checked="" type="radio"/> GAS PRESSURE     |                                    |

Cause: - The link between terminals 9 and 10 has been broken by either the fire alarm or thermal links being activated. The gas valve outputs will be deactivated.  
Solution: - Ensure fire alarm is not activated. Check wiring to fire alarm Interface panel..  
Check if the thermal link circuit has been broken. The system must be reset by pressing "STOP" before it can be restarted.

### 2.04.3 - KNOCK OFF BUTTON

- |                                                   |                                    |
|---------------------------------------------------|------------------------------------|
| <input checked="" type="radio"/> POWER ON         | <input type="radio"/> DETECTOR 1/5 |
| <input checked="" type="radio"/> GAS VALVE        | <input type="radio"/> DETECTOR 2/6 |
| <input checked="" type="radio"/> REMOTE KNOCK OFF | <input type="radio"/> DETECTOR 3/7 |
| <input checked="" type="radio"/> FIRE ALARM       | <input type="radio"/> DETECTOR 4/8 |
| <input checked="" type="radio"/> GAS PRESSURE     |                                    |

Cause: - The link between terminals 11 and 12 has been broken (knock off pressed).  
The gas valve output will be deactivated.  
Solution: - Ensure remote knock off button has been released. Check wiring to remote knock-off button. The system must be reset by pressing "STOP" before it can be restarted.

## 2.04.5 – DETECTOR / SENSOR FAULT

- POWER ON
  - GAS VALVE
  - REMOTE KNOCK OFF
  - FIRE ALARM
  - GAS PRESSURE
-  ANY DETECTOR LED

Cause: - A detector has indicated there is a fault. The gas solenoid valve will be shut down until the fault has been cleared and the system re-started.

Solution: - Check the detector / sensor indicated by the LED. Take adequate precautions in the event of a gas leak and contact a GAS SAFE engineer.

*\*Please note that on systems with 4 or more detectors/sensors they share the LED indication. For example if detector 1 or 5 faults the LED will change to Red.*

## 2.04.6 - GAS PRESSURE FAULT 1

- POWER ON
  - GAS VALVE
  - REMOTE KNOCK OFF
  - FIRE ALARM
  - GAS PRESSURE
- DETECTOR 1/5
  - DETECTOR 2/6
  - DETECTOR 3/7
  - DETECTOR 4/8

Cause: - The system has failed its initial gas pressure test.

Solution: - Ensure all gas appliances are off. Contact a GAS SAFE engineer to check the pressure levels within the pipe work. Check wiring to gas pressure sensor. The system must be reset by pressing "STOP" before it can be restarted.

## 2.04.7 - GAS PRESSURE FAULT 2

- POWER ON
  - GAS VALVE
  - REMOTE KNOCK OFF
  - FIRE ALARM
  - GAS PRESSURE
- DETECTOR 1/5
  - DETECTOR 2/6
  - DETECTOR 3/7
  - DETECTOR 4/8

Cause: - The gas pressure has dropped below 12mbar during normal running.

Solution: - See solution in (2.04.6)

**If the above does not solve your problem, contact Trent Products.**

**Notes:**

FOR FURTHER TECHNICAL ASSISTANCE, PLEASE CONTACT US BY

Phone: 01782 844688

Fax: 01782 844772

E-mail: [info@trentproducts.com](mailto:info@trentproducts.com)

Web site: [www.trentproducts.com](http://www.trentproducts.com)

- Note:
- i) Ensure that the electrical installation has been installed in accordance with the current edition of the IEE regulations.
  - ii) Ensure that the gas installation has been installed in accordance with the current gas regulations and GAS SAFE guide-lines.
  - iii) Ensure that the ventilation and extract system has been set to the correct air flow design levels in accordance with the current regulations.
  - iv) If in doubt, ask! (Contact us on or by any of the above).
  - v) Ensure that the client has been shown how to operate the system and that they have been handed the operator's manual.



This symbol on this product or the package indicates that disposal of this product after its lifecycle could harm the environment.  
DO NOT dispose of this product (or batteries if used) as unsorted municipal waste. It should be disposed by a specialised company for recycling.  
This product should be returned to your distributor or to a local recycling service. Respect the local environment rules.

**TRENT PRODUCTS**  
**Trent House**  
**Dewsbury Road**  
**Fenton**  
**Stoke-on-Trent**  
**Tel: 01782 844688 Fax: 01782 844772**